

de
dragoelectrónica

Metal Free Processes

**METAL DETECTORS AND MAGNETIC FILTERS
FOR FOOD, CHEMICAL, PHARMA AND OTHERS APPLICATIONS.**

METAL DETECTORS AND MAGNETIC FILTERS FOR THE FOOD AND PHARMACEUTICAL INDUSTRIES AND OTHERS.

For more than 40 years, our company has been designing and manufacturing equipment for the detection, removal and/or classification of metals for the protection of crushing machinery and/or final product quality improvement.

The diversity of *Drago Electrónica's* range of equipment when it comes to metal detectors and magnetic separators allows our business to adapt to the requirements of any industry.

Our technical department is prepared to study and resolve any problem with which our customers approach them relating to the removal of contaminant metal particles. We set ourselves apart through our individually tailored approach and by offering an excellent post-sale service to all our customers.



METAL DETECTORS

Our metal detectors stand out due to the following characteristics they possess:

Sensitivity:

Their electronic circuits detect ferrous and non-ferrous metals, from large to very small particles.

Benefits provided:

Protects the final consumer from the presence of metal in their foodstuffs. Qualitative advantages for the final product.

Protects machinery against the infiltration of metals, thus avoiding serious breakdowns.

Optimal integration into your production process:

Adaptable to any stage of the process.

Suitable for all types of transport systems.

Personalized design completely adjusted to your own production process.

Highly developed technology

User-friendly and adjustable product effect compensation and multi-product memory.

Customer support

Consultancy and analysis for products and product testing, machinery testing and end-user training.

Worldwide after-sales service.

GRS MODEL

Metal detector suitable for the cement, mining and other industries.

Metal detector made up of two detector coils, a system that can be dismantled to be inserted into the conveyor belt. Managed by a microprocessor, it has extremely high sensitivity and stability.

Sensible to all the metals, ferrous and non-ferrous.

Possible automatic separation of the contaminated product without stopping the manufacturing process – with separation mechanism on the conveyor belt.

Possibility certification ATEX ZONE 22 AND ZONE 21 CERTIFICATION.

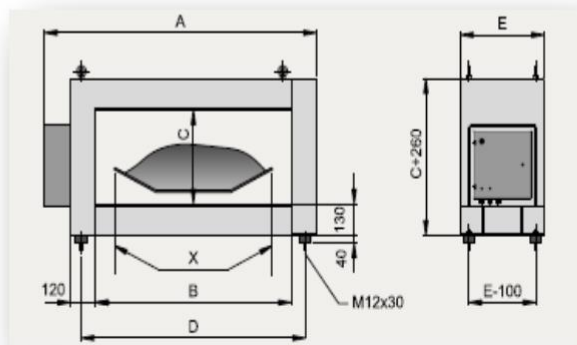

Type GRS - Standard dimensions (in mm.)

	300	400	500	650	800	1000	1200	1400	1600	1800	2000
X	300	400	500	650	800	1000	1200	1400	1600	1800	2000
A	900	1000	1100	1250	1400	1600	1800	2000	2200	2400	2600
B	500	600	700	850	1000	1200	1400	1600	1800	2000	2200
C	From 200 to 1000 mm.										
D	640	740	840	990	1140	1340	1540	1740	1940	2140	2340
E	400	400	400	400	500	500	500	600	600	700	700

GRSC MODEL

Metal detector suitable for Food Industry.

Easily integrated into production lines. The highest performance in detecting magnetic and non-magnetic metals. Minimum number of false detections (due to analogue and digital filters).

Can be used as a systematic solution, in combination with conveyor belt and automatic rejection systems. The rejection system removes the contaminated product automatically without halting the production process. Fast and safe ejection of the contaminated product.

Design and conception to comply in accordance with the HACCP and IFFAS recommendations.

By using the RS232 or RS485 communication or Ethernet you can track detections, print reports and modify the basic parameters through the remote access via personal computer. More important parameters of a detector are protected by a password. Possibility to enter 30 different setting for products.

High sensitivity and stable operability. Stainless Steel AISI 316L construction. Possibility of integrated or separate electrical equipment. Simple replacement of the power supply or processing module in case of malfunction.



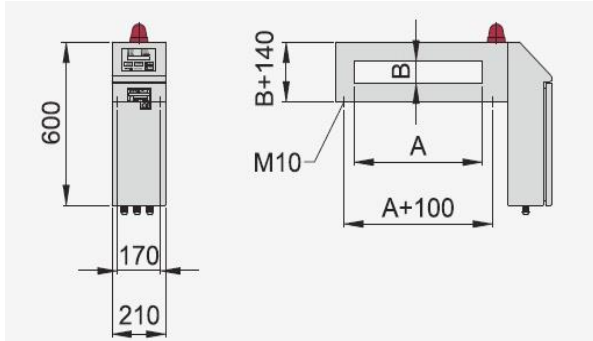

Type 210 GRSC

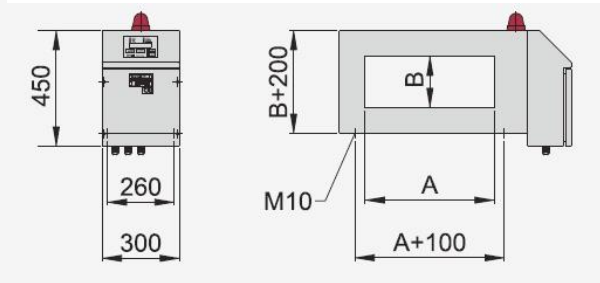

Type 300 GRSC

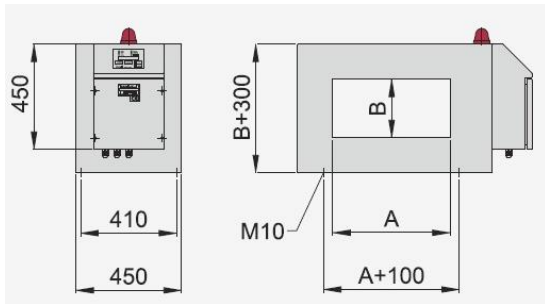

Type 450 GRSC

Type GRSC - Standard dimensions (in mm.)												
	A	100	150	200	250	300	350	450	550	700	850	1050
Type 210 GRSC	B	50, 60, 70, 80										
Type 300 GRSC	B	90, 100, 125, 150, 200										
Type 450 GRSC	B	250, 300										

GRSC MODEL WITH CONVEYOR BELT

Metal detector suitable for Food Industry.

Easily integrated into production lines. The highest performance in detecting magnetic and non-magnetic metals. Minimum number of false detections (due to analogue and digital filters).

Can be used as a systematic solution, in combination with conveyor belt and automatic rejection systems. The rejection system removes the contaminated product automatically without halting the production process. Fast and safe ejection of the contaminated product.

Design and conception to comply in accordance with the HACCP and IFFAS recommendations.

By using the RS232 or RS485 communication or Ethernet you can track detections, print reports and modify the basic parameters through the remote access via personal computer. More important parameters of a detector are protected by a password. Possibility to enter 30 different setting for products.

High sensitivity and stable operability. Stainless Steel AISI 316L construction. Possibility of integrated or separate electrical equipment. Simple replacement of the power supply or processing module in case of malfunction.



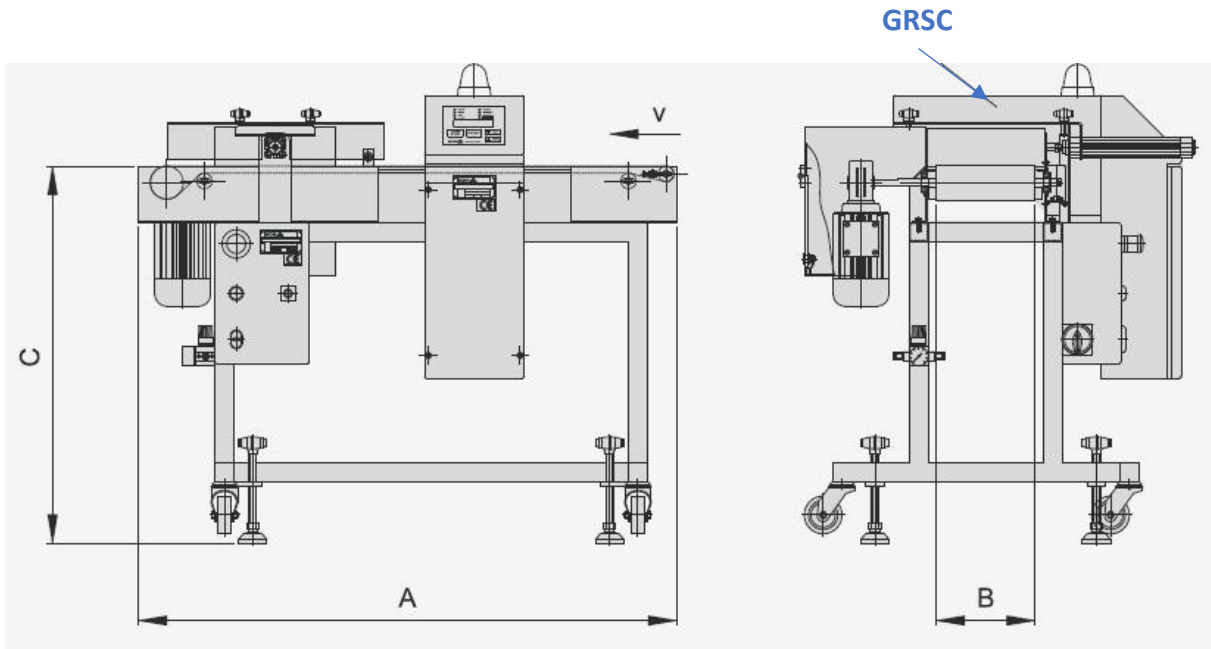

AUTOMATIC DETECTION-BASED REJECTION SYSTEMS

Ejector arm

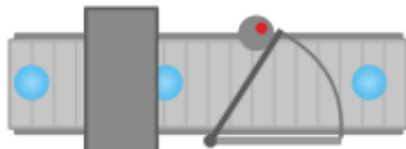

Pusher arm

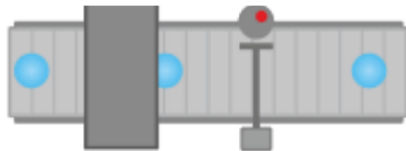

Compressed air



Retractable conveyor belt

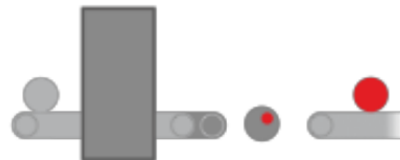

Folding conveyor belt

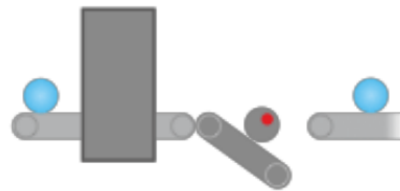

GRF MODEL. Tubular metal detector without by-pass

Metal detector suitable for Food Industry and others.

Easily integrated into production lines. The highest performance in detecting magnetic and non-magnetic metals. Minimum number of false detections (due to analogue and digital filters).

Installation in a free-falling system for powder or granulated materials. Requires very small space for installation. Customization to the customer needs.

Compliance with the HACCP and IFFAS requirements.

Accurate manual or automatic product compensation (self-learning). Using RS232 or RS485 communication or Ethernet, customer can track detections, print reports and modify the basic parameters through the remote access via personal computer.

Possibility to enter 30 different settings for products. Clear and simple to use multi-level menus.

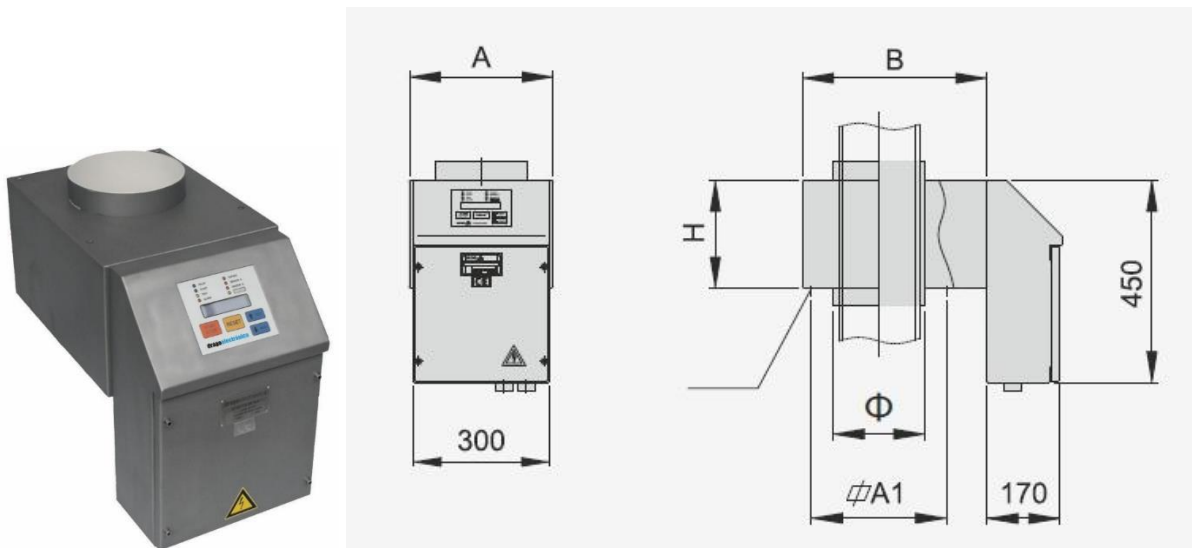

STANDARD DIMENSIONS

Type	Ø	A	B	H	A1
GRF 100	100	210	280	180	170
GRF 150	150	260	350	210	220
GRF 200	200	320	410	240	280
GRF 250	250	380	470	280	340

GRM MODEL. Tubular metal detector with by-pass.

Metal detector suitable for Food Industry and others.

Automatic separation of the product contaminated with metal. Fast and safe ejection of the contaminated product – the minimum product lost.

Installation in a free-falling system for powder or granulated materials. Possible in combination with a magnetic filter.

Customization to the customer needs.

Compliance with the HACCP and IFFAS requirements. The highest performance in detecting magnetic and non-magnetic metals.

Accurate manual or automatic product compensation (self-learning). Using RS232 or RS485 communication or Ethernet, customer can track detections, print reports and modify the basic parameters through the remote access via personal computer.

Possibility to enter 30 different settings for products. Clear and simple to use multi-level menus.



Metal detector with magnetic grid.

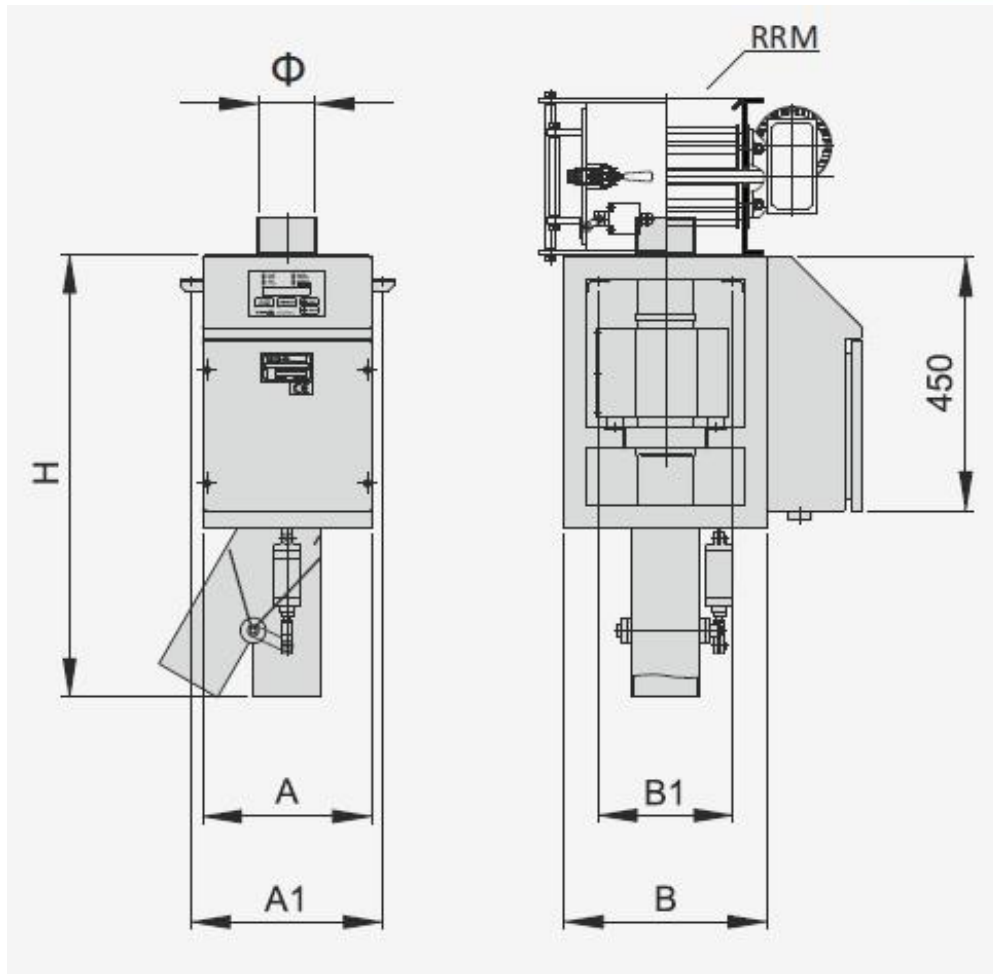

STANDARD DIMENSIONS

Type	Φ	A	B	H	A1	B1
GRM 100	100	300	350	800	300	300
GRM 150	150	400	450	900	440	400
GRM 200	200	450	500	1000	490	450
GRM 250	250	500	550	1100	540	500

GEP MODEL. Metal detector for pastry products.

Metal detector suitable for Food Industry and others.

Installation in horizontal or vertical pressure systems. Possibility to installing an automatic separation system GEPS.

The discharge mechanism is adapted for pressures filling machines (particularly in the meat industry).

Round opening.

Suitable for cleaning with water. Customization to the customer needs.

Compliance with the HACCP and IFFAS requirements. The highest performance in detecting magnetic and non-magnetic metals.

Accurate manual or automatic product compensation (self-learning). Using RS232 or RS485 communication or Ethernet, customer can track detections, print reports and modify the basic parameters through the remote access via personal computer.

Possibility to enter 30 different settings for products. Clear and simple to use multi-level menus.



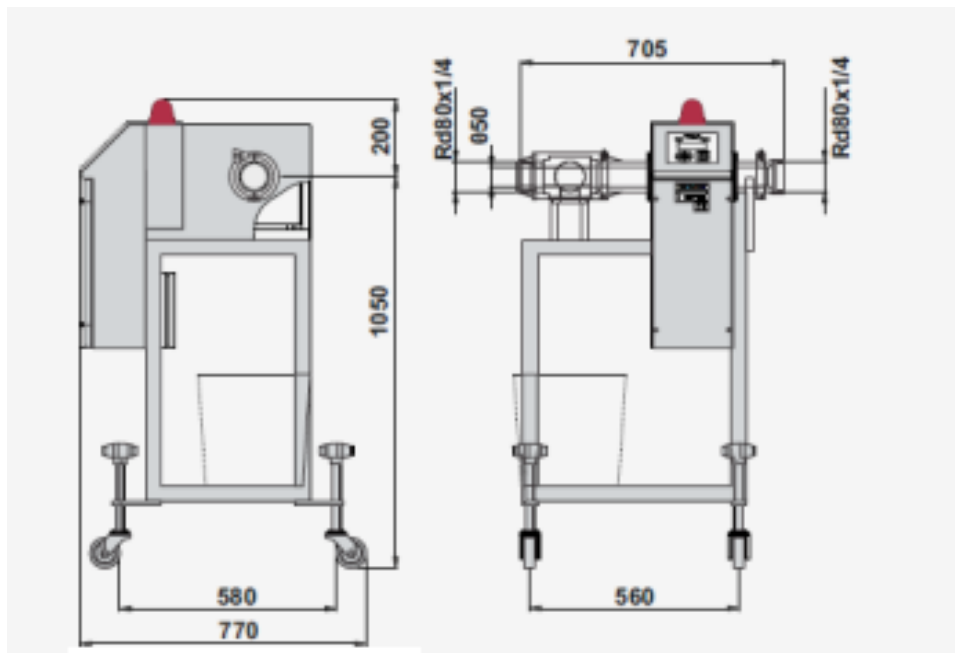

GEP metal detector

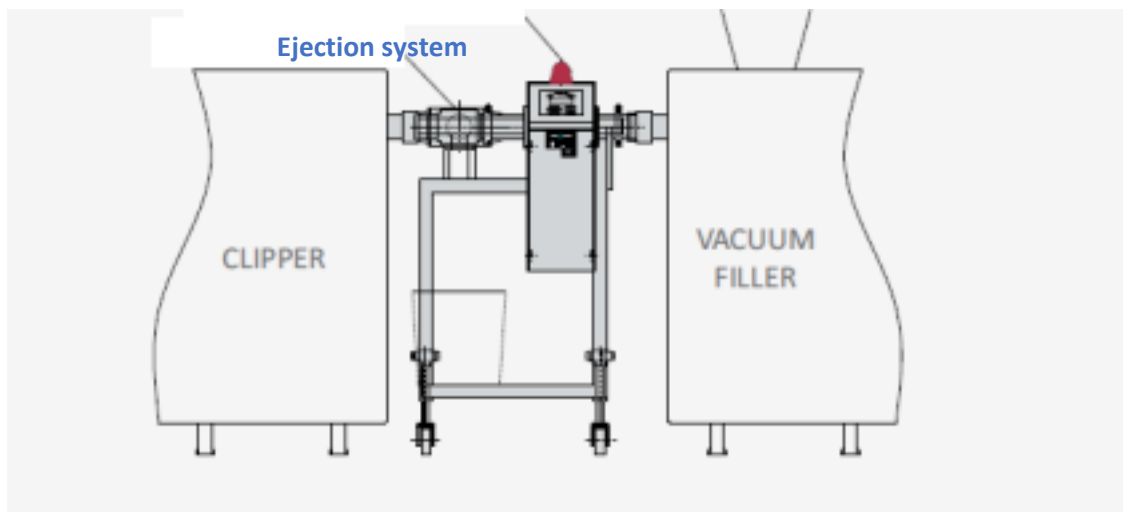

Vacuum Fillers		Clippers	
Handtmann	VF 12-24, VF 50-300	Poly-Clip	FCA, DFC, DCE
Handtmann	HVF 90	Pipper/Tie	KDC, DCA
Tiereeder	1000 – 3000, Robbys, Robot	Tecnopack	DKF
Vemag	HP&DP		
Risco	2000, 4001, 5000		
Alpina	DKF		
Karl Schnell	573 – 594, P7 – P11		

GEF MODEL. Metal detector Pharma Industry.

Metal detector suitable for Pharma Industry.

Automatic separation of the pill contaminated with metal. The highest performance in detecting magnetic and non-magnetic metals.

Extremely fast pneumatic ejection hatch. Application at the end of a tablet machine.

Possibility of an upgrade with a duster (cleaning of products, including their residues and dust).

Customization to the customer's needs. The highest performance in detecting magnetic and non-magnetic metals.

Accurate manual or automatic product compensation (self-learning). Fast and safe ejection of the contaminated product.

Minimum number of false detections (due to analogue and digital filters). By using the RS232 or RS485 communication or Ethernet you can track detections, print reports and modify the basic parameters through the remote access via personal computer.

The possibility to enter 30 different settings for products. Clear and simple-to use multi-level menus. Simple assembly, disassembly and cleaning. Casing from high quality stainless steel or from quality sheet metal.



STANDARD DIMENSIONS

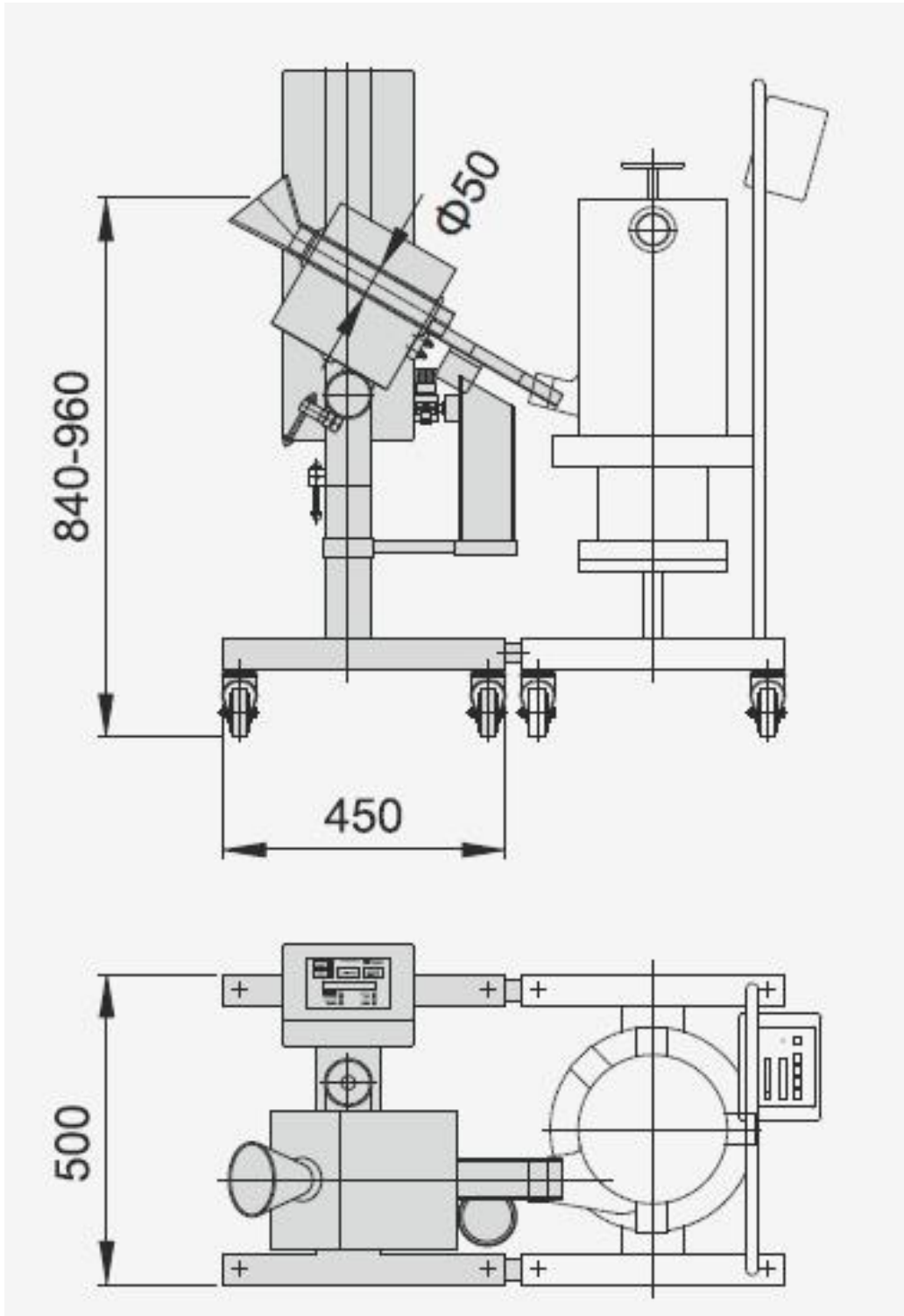

MAGNETIC FILTERS

Our magnetic separators stand out due to their following main features:

Efficiency:

These are entirely automatic magnetic filtration and purification systems, with barely any interruptions in operability from installation onwards.

Attributes:

Protects the final consumer from the presence of metal in their foodstuffs.

Qualitative advantages for the final product.

Protects machinery against the infiltration of metals, thus avoiding serious breakdowns.

Optimal integration into your production process:

Adaptable to any stage of the process.

Suitable for all types of transport systems.

Personalized design completely adjusted to your own production process.

Highly developed technology

Effective separation even for the smallest ferromagnetic particles. User-friendly and easily adjustable.

Customer support

Consultancy and analysis for products and product testing, machinery testing and end-user training.

Worldwide after-sales service.

MAGNETIC FILTERS AND GRID

Magnetic Filters: This kind of magnetic filter does not consume energy; it does not need auxiliary equipment and maintenance is limited to only the removal of attracted contaminating particles.

Magnetic Grids: The location of this kind of grid can vary greatly. They are normally located at the entrance of the hoppers, pipes, or canals. Its function is to separate ferrous metal circulating through these systems. The careful selection of grill dimensions ensures minimum resistance to the flow of material. They do not consume energy and are easy to clean.

Semi-self-cleaning Grids and Filters: They do not consume energy and are very easy to clean. Thanks to the correct study and positioning of the magnetic bars, cleaning is extremely simple. It is enough just to remove the grid or filter from the drawer and clean it with a cloth or with compressed air.

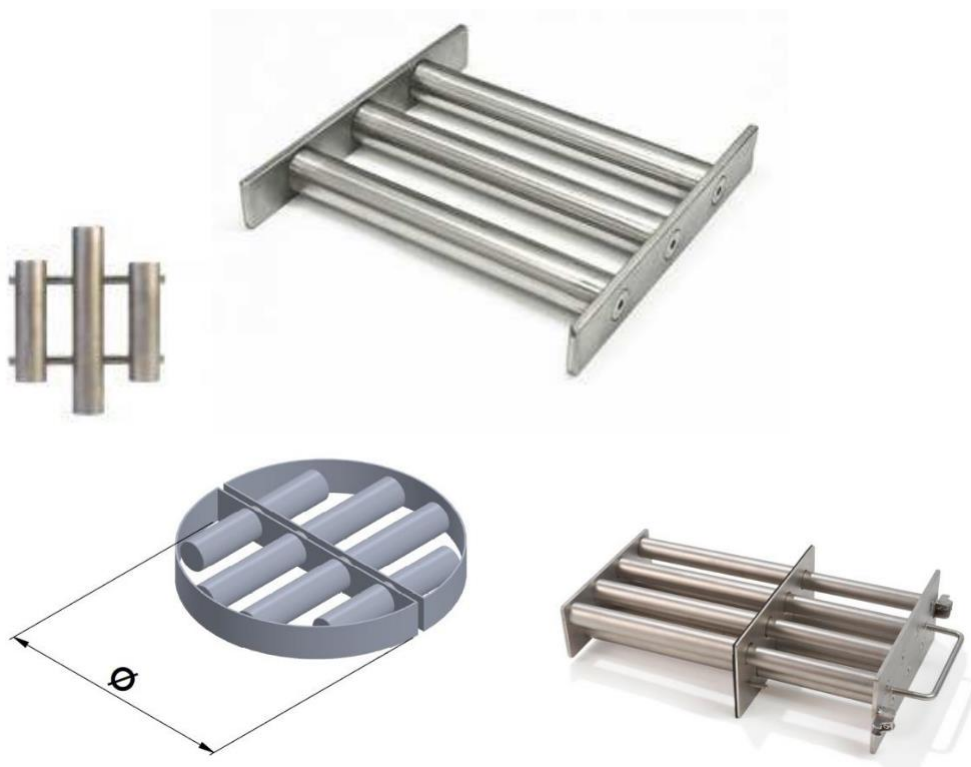

RME MAGNETIC GRID

Extraction of extremely small, fine ferromagnetic particles in powdery or granulated products.

Installation in vertical piping (free-falling material). Adjustable according to the type of raw material and transport features.

Manual or automatic cleaning (through hydraulic or pneumatic systems).

During cleaning, the magnetic elements are extracted from the protector tube, so as the ferromagnetic material is deposited in the container designed for this purpose.



Model	A	B	C	D	E	Weight
RME60	100	100	195	60	282	7 Kg.
RME80	100	100	195	80	282	7,5 Kg.
RME100	100	100	195	100	282	8 Kg.
RME125	172	172	267	125	282	12 Kg.
RME160	172	172	267	160	282	13 Kg.
RME180	232	232	327	180	282	16 Kg.
RME200	232	232	327	200	282	18 Kg.

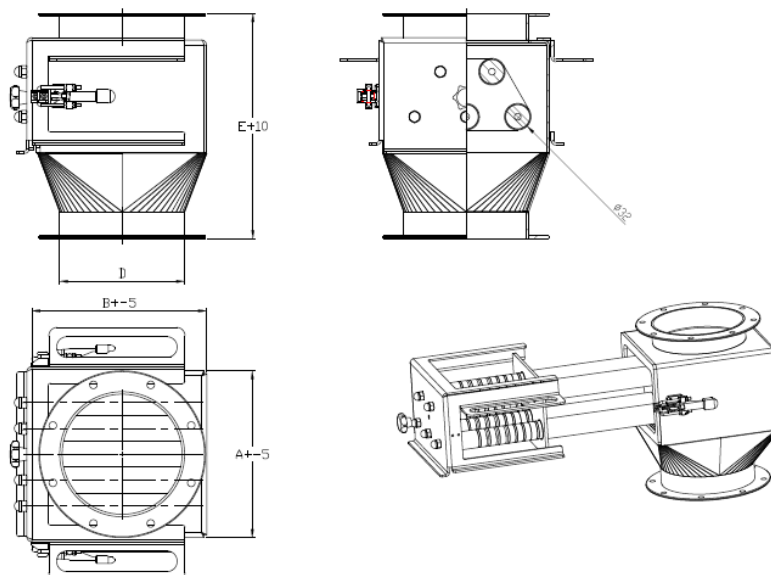

RMC MAGNETIC GRID

Very effective separation of small ferromagnetic particles and oxides larger than 10 µm from free-falling dry materials or from pressured air transport.

Strong neodymium NdFeB magnets type N52 (14.800 Gauss, on contact).

Dimensions and design of magnetic filter can be adjusted to customer needs, manual and easy cleaning system, during cleaning, the magnetic elements are pulled out of protective pipes, so that the ferromagnetic material can fall into a prepared container or funnel.



RRM MAGNETIC GRID

Remove metal contaminants and avoid damage to the molding-injection devices, thrust systems, cylinders, mixing machines, presses, and other equipment. The metal contaminants thus pose a problem, due to which the quality of the products reduces, or the manufacturing process stops.

The RRM rotating magnetic grates and MFC conduit magnetic filters ensure a separation of metallic contaminants. This is very important in the manufacturing of plastics.

Rotating magnetic grates are particularly suitable for the application in the food industry, namely for products such as sugar, flour, powdered milk and similar.

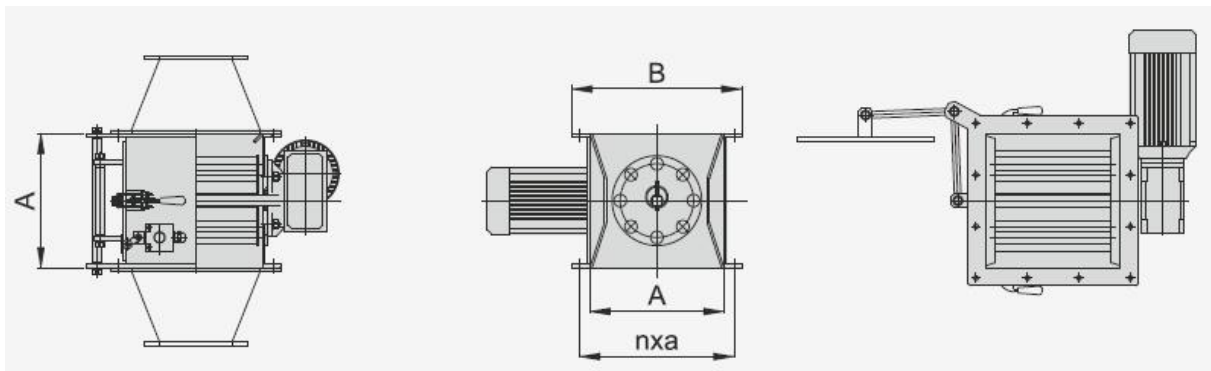
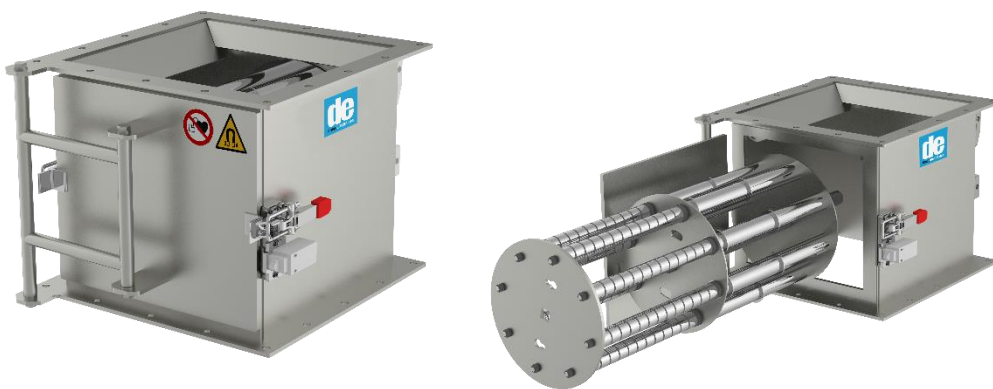

Model	A	B	n	a	d
RRM -200	200	260	2	115	9
RRM -250	250	310	3	93	9
RRM -300	300	380	3	115	11
RRM -350	350	440	4	100	11

MRRV MAGNETIC GRID

Remove extremely small fine ferromagnetic particles from powders or granulates.

Installation in vertical pipes or in places where the materials are in free fall. Possibility to adjusting the capacity to the type of raw material and transport requirements.

Manual cleaning or automatic cleaning with a pneumatic or hydraulic system.

During cleaning, the magnetic elements are pulled out of the protective pipe, so that the ferromagnetic material can fall into a prepared container of funnel.

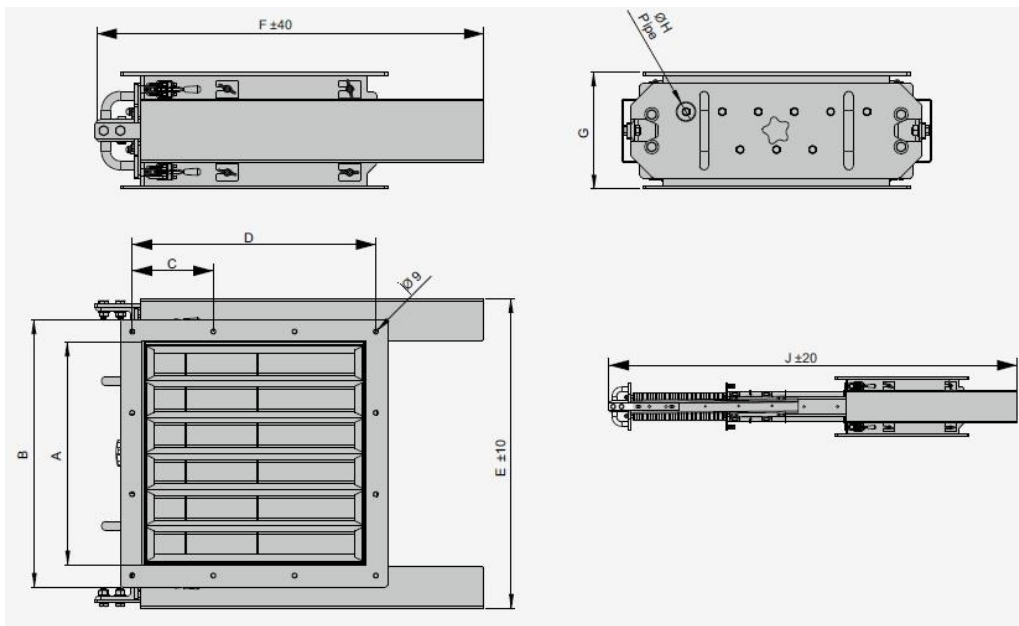

Type	A	B	C	D	E	F	G	H	J	Weight
MRRV 250 N52	250	330	143	286	550	405	210	Ø35	1370	39 Kg.
MRRV 300 N52	300	380	168	336	600	455	210	Ø35	1420	48 Kg.
MRRV 350 N52	350	430	128	384	650	505	201	Ø35	1470	57 Kg.
MRRV 400 N52	400	480	146	438	700	555	210	Ø35	1520	66 Kg.

MRRAA MAGNETIC GRID

Automatic separation of ferromagnetic contaminants.

Custom made, customization to the customer's needs.

Smooth separation of the metal impurities – possible to separate also metal impurities bigger than 5 µmm.

Smooth flow of material through central part of the magnetic separator. Metal impurities caught in the middle part of the separator, are eliminated automatically at given intervals. They are eliminating in the left or right area of separator without interrupting or stopping the production process.

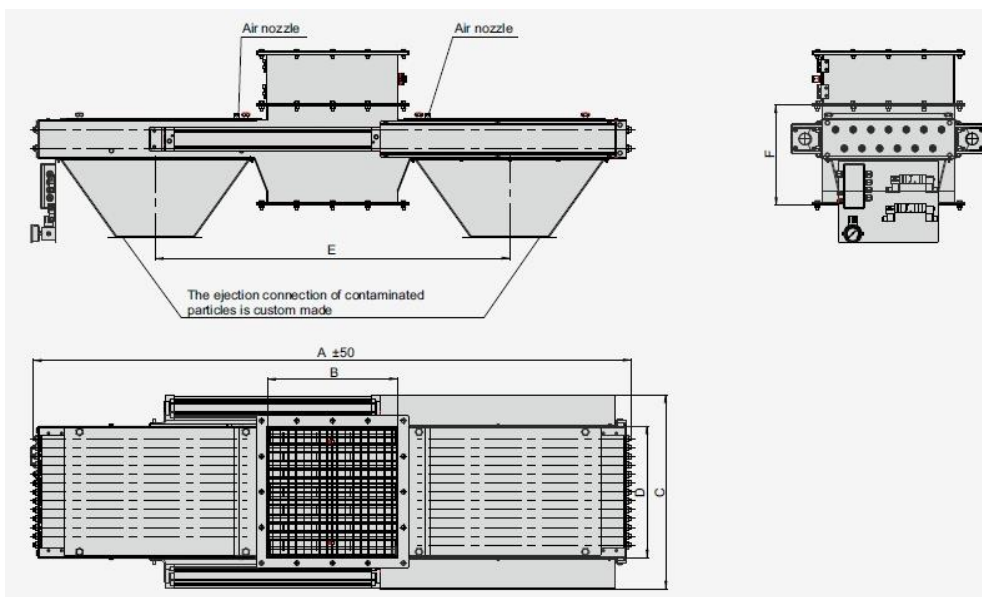

Type	A	B	C	D	E	F	G	H	Weight
MRRAA 300 N52	1700	300	550	306	965	380	386	115,3x3	140 Kg.
MRRAA 400 N52	2000	400	650	406	1165	380	486	111,4x4	190 Kg.
MRRAA 500 N52	2300	500	750	506	1365	380	586	136,5x4	240 Kg.

MFC MAGNETIC FILTER FOR LIQUIDS

Magnetic filters for liquids are used for separating ferrous particles in liquid, thick or chunky products. They are also very often used in hydraulic circuits and refrigeration systems.

Extremely efficient operability. Their structure and finish make cleaning the magnetic bars extremely fast and simple. This type of filter can be manufactured with any dimensions.

Stainless steel design (AISI 304/316) suitable for the food industry.

On request, special flanges can be included to allow for exposure to high pressures. Depending on requirements, the magnetic force can be increased and the working temperature can also be increased up to a maximum of 150°C.

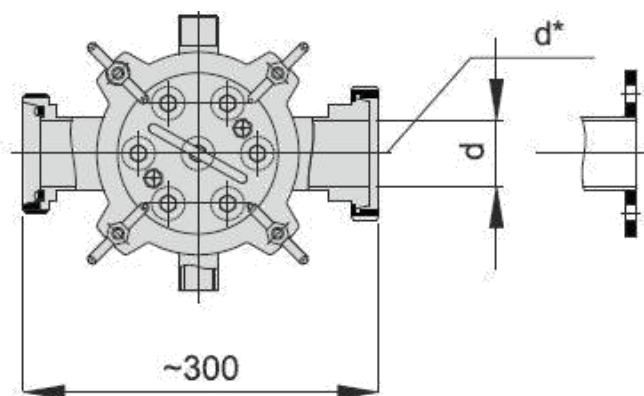
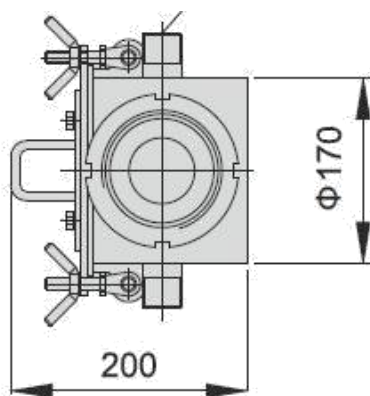

PMS MAGNETIC CASCADE SEPARATOR

New solution for vertical air transport (up flow of the material). Very robust, for heavy working conditions, but adjusted to customer working line.

With new automatic cascade magnetic separator, can be automatically extracted micron ferromagnetic particles from woodchips that are being transported into the silos.



Cleaning system



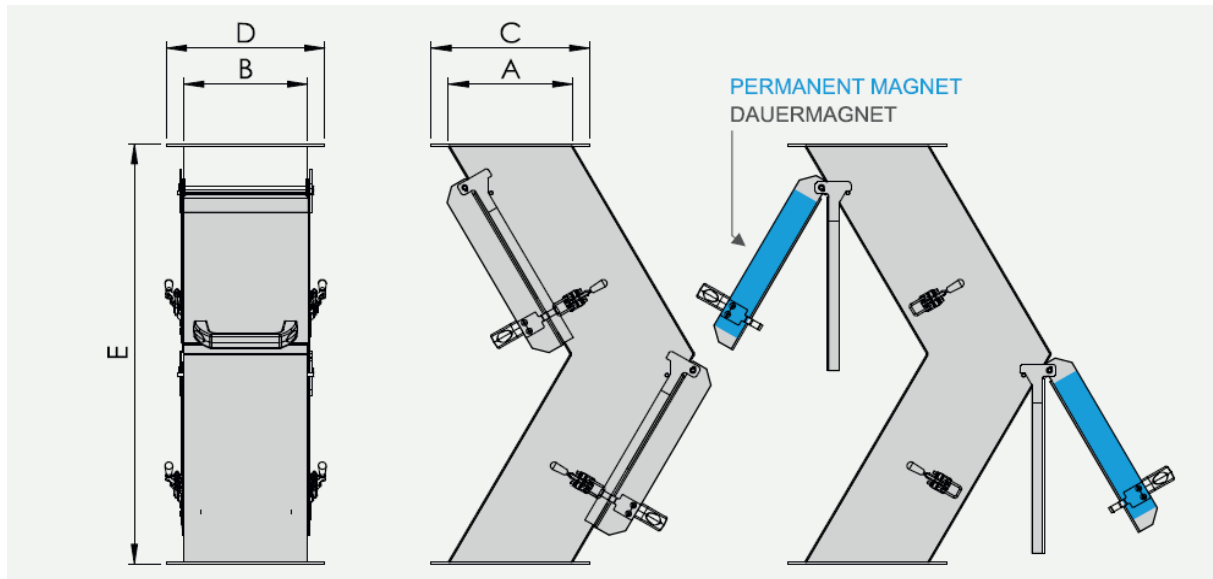

Type	A	B	C	D	E	Weight
PMS-200/700	200	200	260	260	700	45 Kg.
PMS-250/700	200	250	260	310	700	55 Kg.
PMS-300/700	200	300	260	360	700	65 Kg.
PMS-350/700	200	350	260	410	700	75 Kg.
PMS-400/800	250	400	310	460	800	90 Kg.
PMS-500/800	250	500	310	560	800	110 Kg.
PMS-600/800	250	600	310	760	800	200 Kg.